

button-fix™ the secret fixing for panels

BUTTON MOULDING

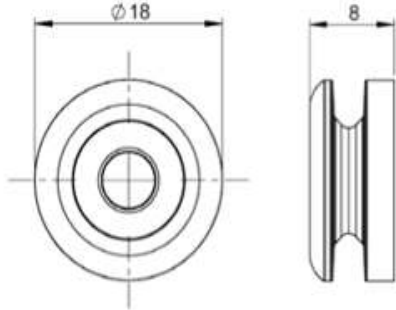

TYPE 1 FIX MOULDING

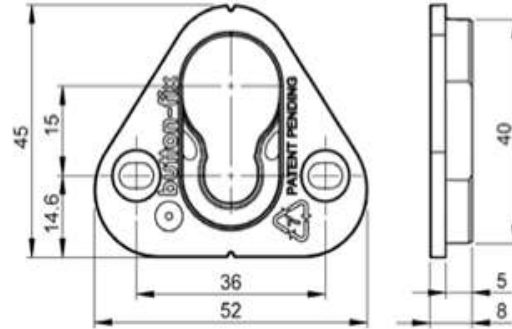

TYPE 2 FIX MOULDING

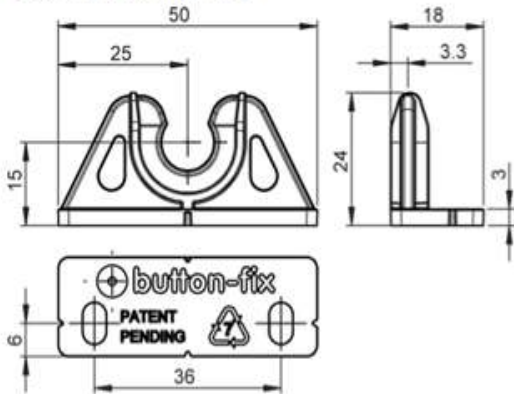

button-fix™ the secret fixing for panels

The concept is simple: durable nylon Buttons are attached to one panel and the mating Fixes are attached to the other. Bring the panels together until the Button-fixes 'click'.

The Button-fix range offers a choice of fixing sets:

The **Type 1 Fix** is either surface-mounted or rebated into the panel, and orientated for vertical or sideways assembly.

Our **NEW Type 2 Fix** also connects panels at 90°, allowing for direct push/pull access. Full details of suggested configurations are illustrated below, together with useful tips and accessories.

The button ▾

Lime green button for use with
Ø5mm countersunk wood screw

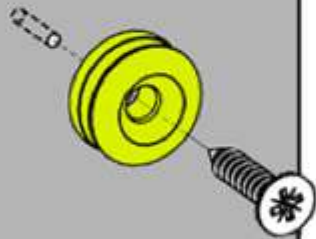

Orange button for use
with Ø6.2mm Euro screw

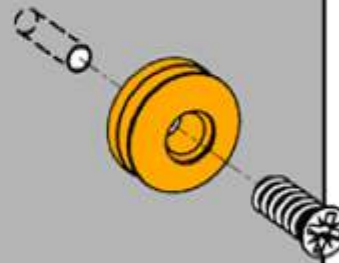

Type 1 fix ▾

The **Type 1 Fix** is surface-mounted or rebated into the panel, and orientated for vertical or sideways assembly, requiring a 15mm clearance to engage. Ideal for applications where strength and security are paramount.



button-fix™ the secret fixing for panels

- surface-mounted ▾

BUTTON ON REMOVABLE PANEL

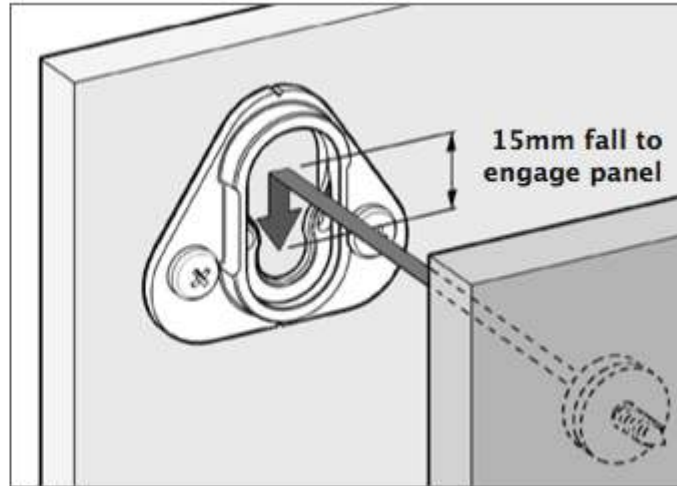
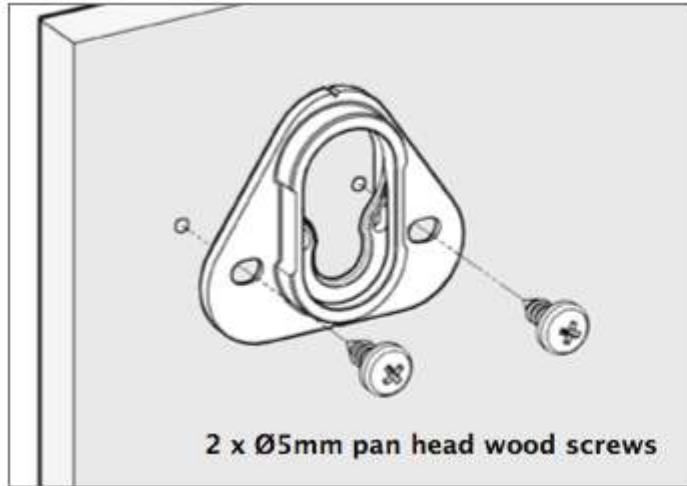

Panel drilling pattern

- Surface-mounted Type 1 Fix
- Button on removable panel

Surface-mounting creates an 8mm gap between the two panels.

Always allow at least 15mm clearance above the removable panel.

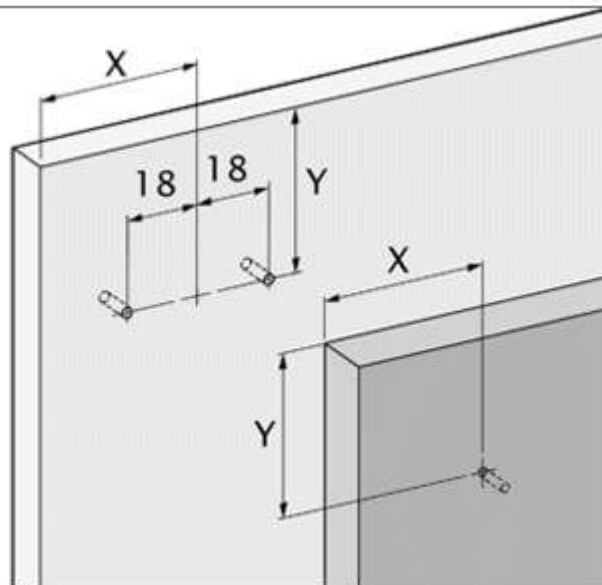

button-fix™ the secret fixing for panels

- surface-mounted ▾

FIX ON REMOVABLE PANEL

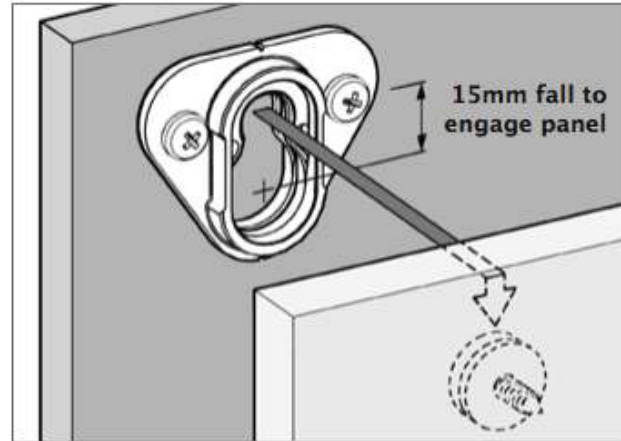
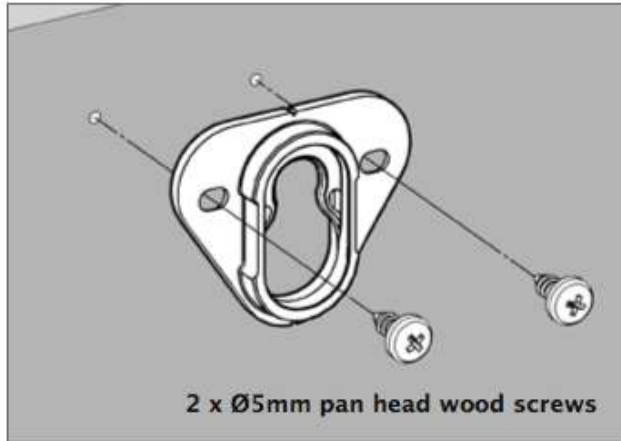

Panel drilling pattern

- Surface-mounted
Type 1 Fix
- Fix on removable panel

Surface-mounting creates an 8mm gap between the two panels.

Always allow at least 15mm clearance above the removable panel.

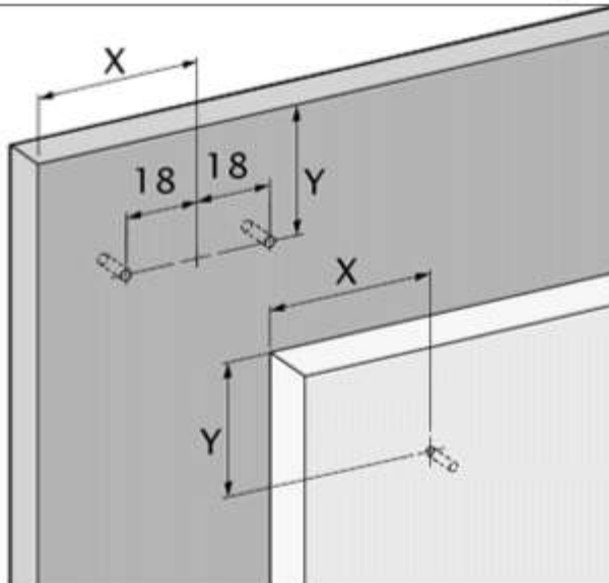

button-fix™ the secret fixing for panels

- surface-mounted ▾

SIDEWAYS ARRANGEMENT

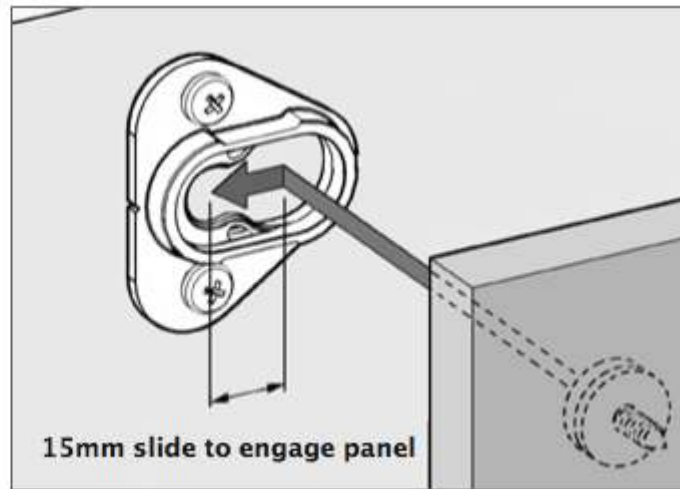
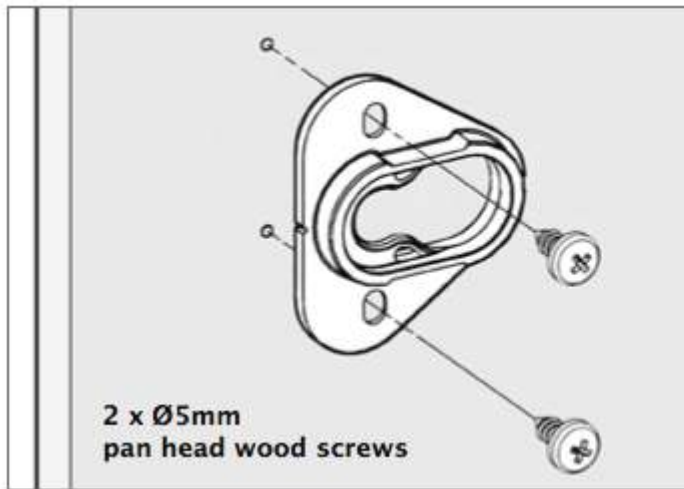

Panel drilling pattern

- Surface-mounted
Type 1 Fix
- Sideways arrangement

Surface-mounting creates an 8mm gap between the two panels.

Always allow at least 15mm clearance above the removable panel.

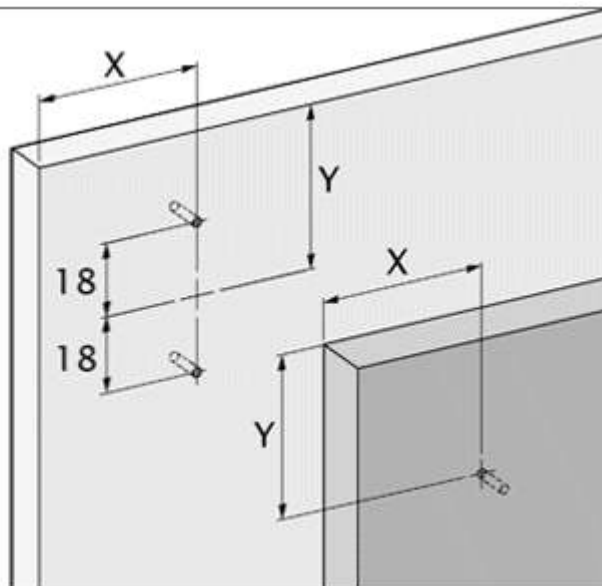

button-fix™ the secret fixing for panels

rebated

BUTTON ON REMOVABLE PANEL

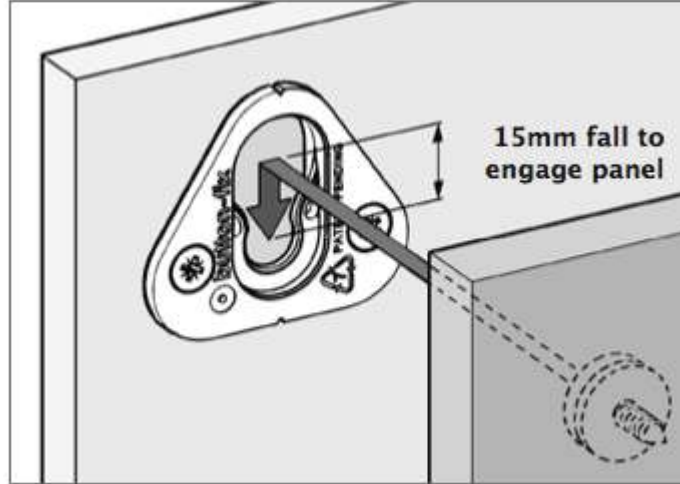
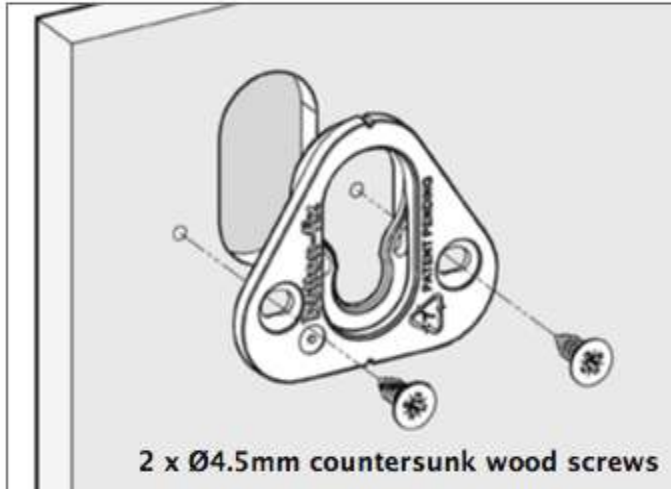

Panel drilling pattern

- Rebated Type 1 Fix
- Button on removable panel

Rebating the Fix creates a 3mm gap between the two panels.

Always allow at least 15mm clearance above the removable panel.

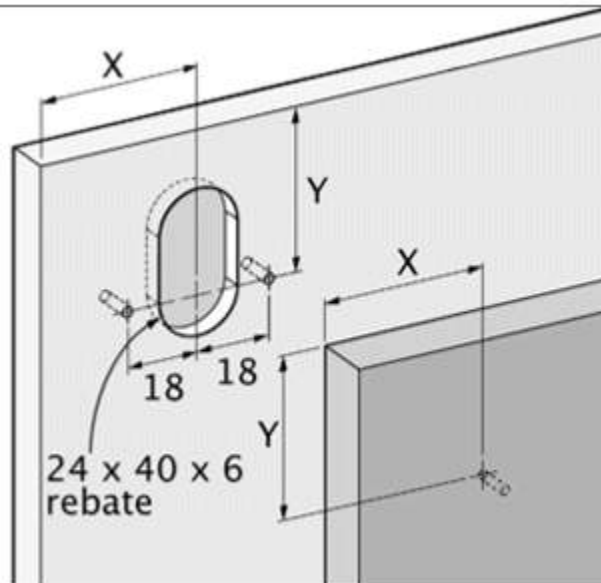

button-fix™ the secret fixing for panels

rebated

FIX ON REMOVABLE PANEL

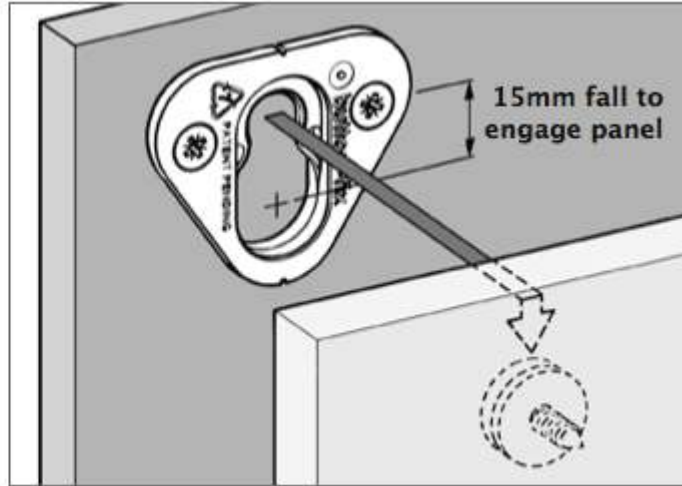
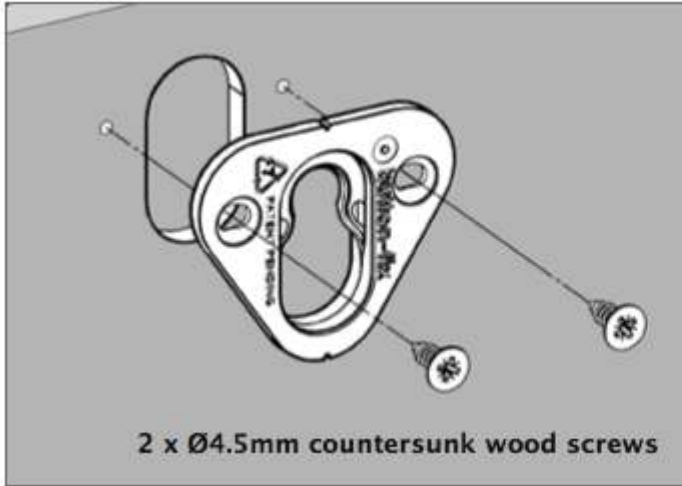

Panel drilling pattern

- Rebated Type 1 Fix
- Fix on removable panel

Rebating the Fix creates a 3mm gap between the two panels.

Always allow at least 15mm clearance above the removable panel.

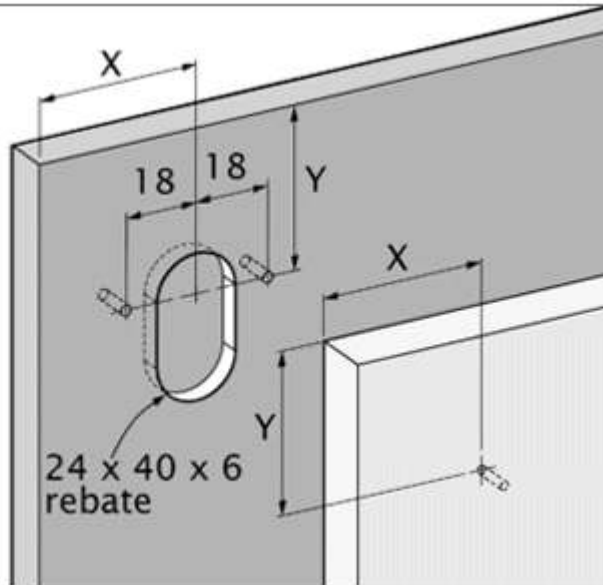

button-fix™ the secret fixing for panels

rebated

SIDEWAYS ARRANGEMENT

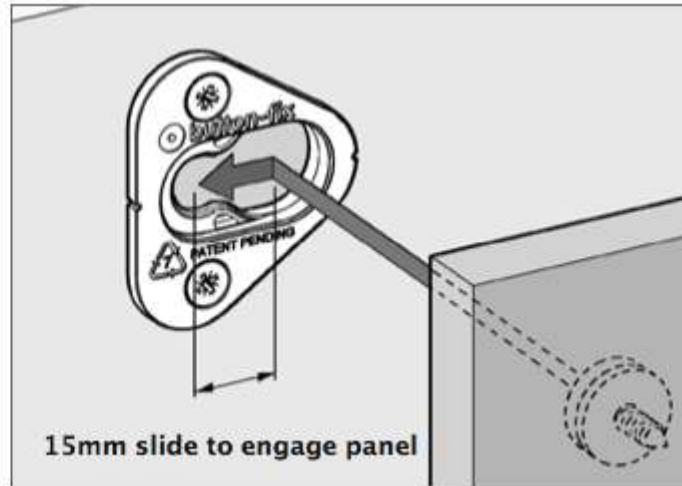
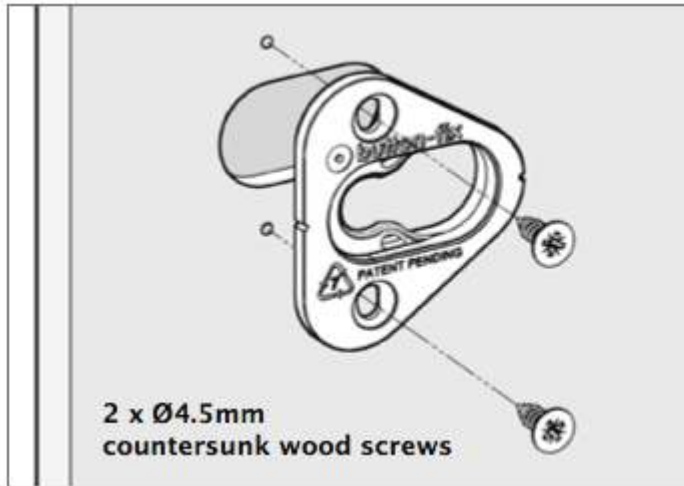

Panel drilling pattern

- Rebated Type 1 Fix
- Sideways arrangement

Rebating the Fix creates a 3mm gap between the two panels.

Always allow at least 15mm clearance above the removable panel.

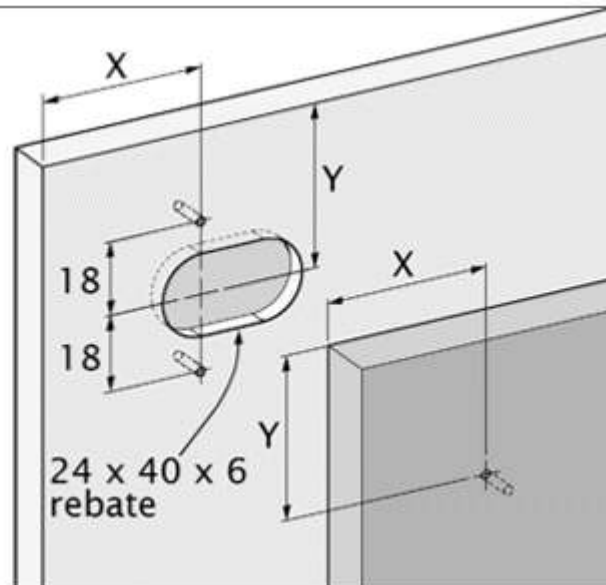

button-fix™ the secret fixing for panels

suggested button layout on a panel

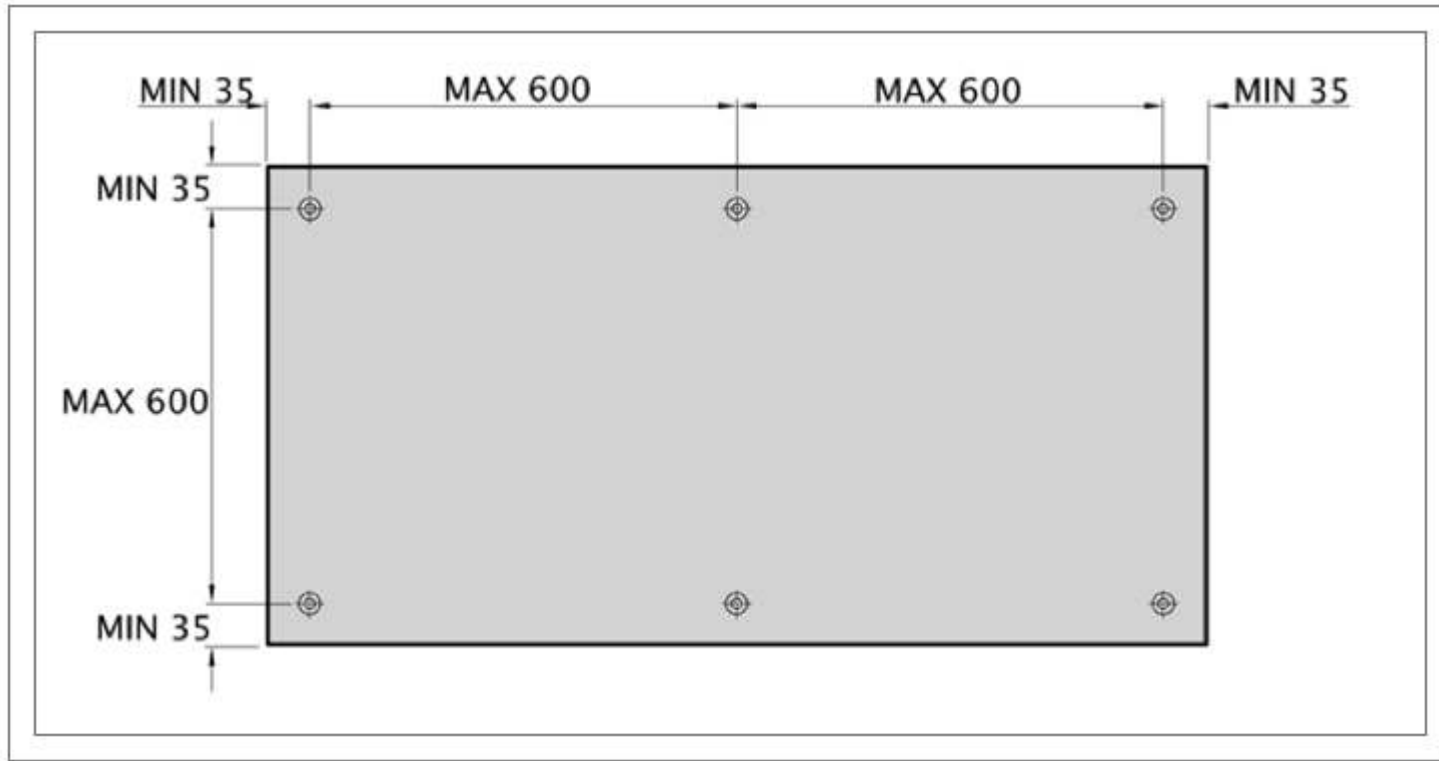

button-fix™ the secret fixing for panels

Type 1 button marker accessory

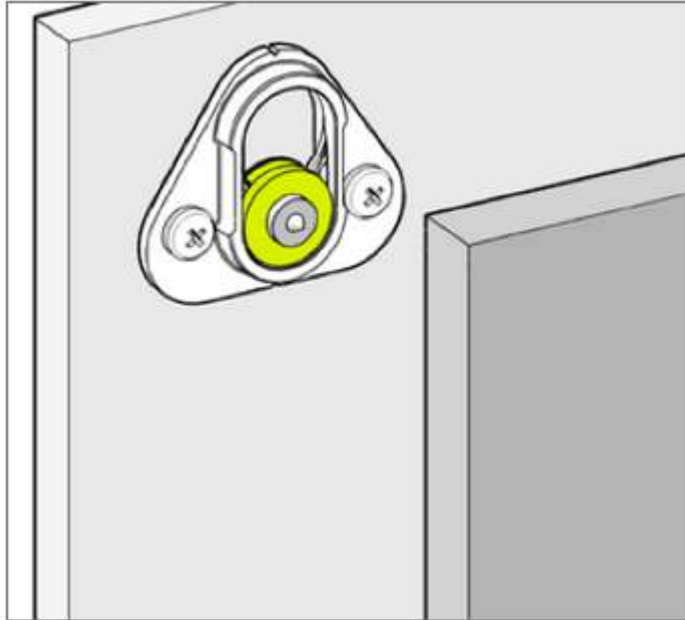

The Button marker accessory helps to mark out where to install the Buttons. Once you have attached the Fix mouldings, snap a marker into each one. Then position the removeable panel where desired and press firmly. The markers will leave indents in the panel surface, which can be used as guides for drilling pilot holes for the Buttons.



Remove the markers, which can be re-used when marking out the next panel. Always remember to allow at least 15mm clearance above the removeable panel. Please note that Button marker accessories need to be ordered separately from the Button-fixes.

button-fix™ the secret fixing for panels

useful tips (Type 1)

When several Button-fixes are used on a panel or if you require the panel to be easily removable, you may wish to reduce the strength of the click-fit. To achieve this, adapt some (but not all) the Fix mouldings by popping out the ears with a flat screw driver, as shown in the diagram on the right.

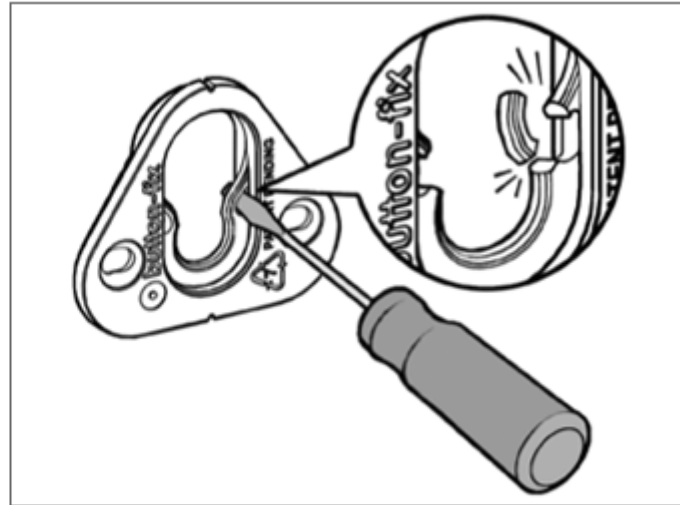

button-fix™ the secret fixing for panels

Type 2 fix

The **Type 2 Fix** is for mounting panels at 90°. Ideal for applications where the emphasis is more on ease of fit and less on strength; a simple push/pull fit, it does not require the 15mm drop-down engagement as on the Type 1 Fix.



FIX ON OVERFLYING PANEL

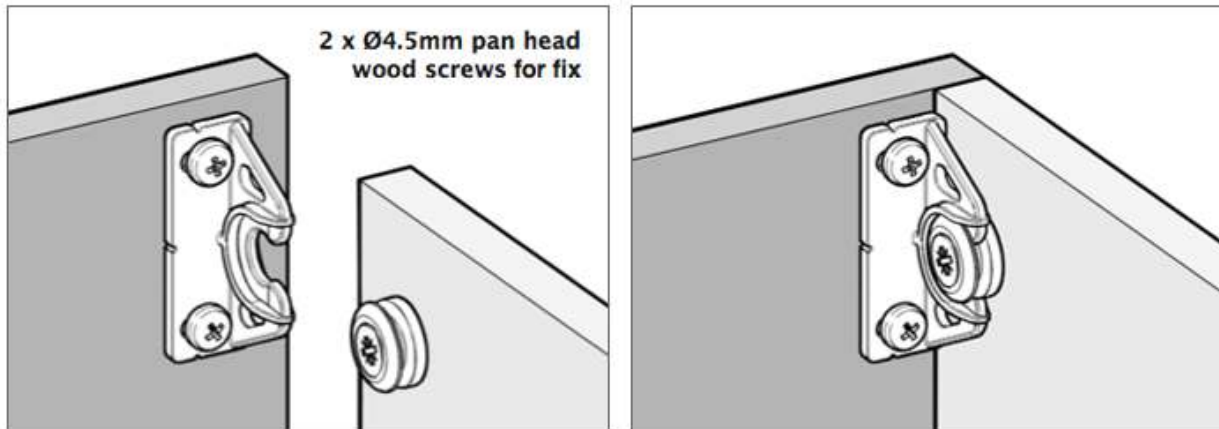

Panel drilling pattern

- Type 2 Fix
 - Overflying panel
- Drill pilot holes if necessary to suit the fixings used.

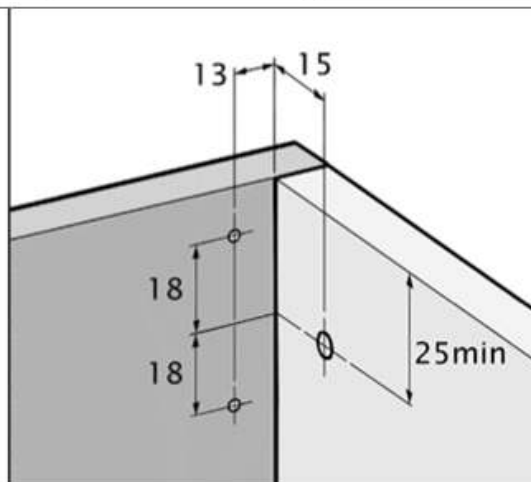

button-fix™ the secret fixing for panels

Type 2 fix

The **Type 2 Fix** is for mounting panels at 90°. Ideal for applications where the emphasis is more on ease of fit and less on strength; a simple push/pull fit, it does not require the 15mm drop-down engagement as on the Type 1 Fix.



FIX ON INTERNAL PANEL

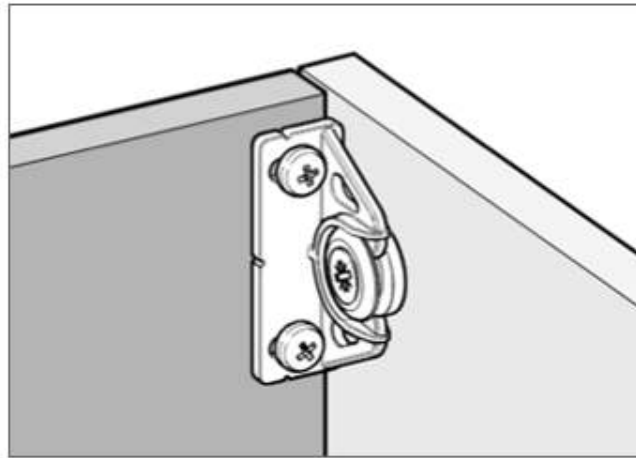
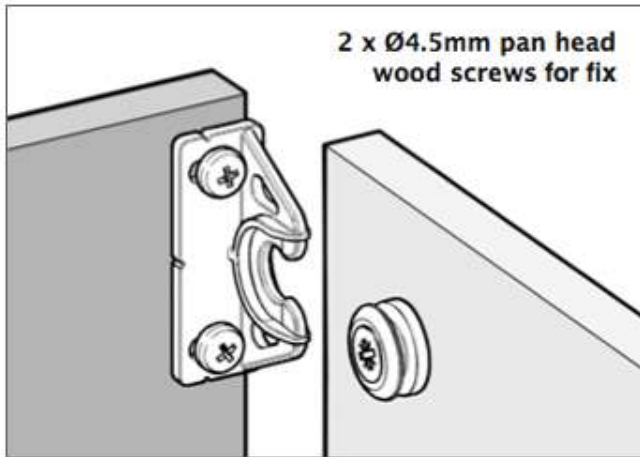

Panel drilling pattern

- Type 2 Fix
- Internal panel

Drill pilot holes if necessary to suit the fixings used.

* Indicated dimensions create a nominal 1mm clearance between removeable and side panels.

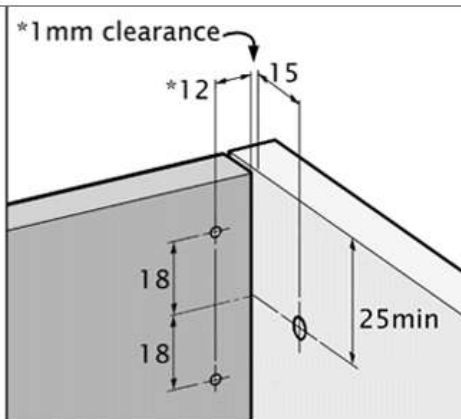

button-fix™ the secret fixing for panels

suggested fix layout on a panel

